



2023-24 Design, Build, Fly Q&A #2



General Questions

1. Does the aircraft need to enter the “parking space” with its wings perpendicular to the longitudinal axis of the parking space?

Answer: The orientation of the airplane in the parking configuration in the parking spot is up to each team to determine.

2. Are hatch mechanisms required to be single-pivot? Can multi-element linkages or sliding mechanisms be used? If so, what is defined as the hinge location, in relation to the aircraft’s centerline?

Answer: The type of hinge or hatch opening mechanism is up to each team to determine. The mechanism and hatch opening must be on the same side of the airplane as defined in the updated rules and Q&A#1.

3. Can you have a row of passenger’s right side up with another row upside down underneath?

Answer: No.

4. Would a hatch design (image below) be legal, specifically the hatch extending onto the top of the fuselage, but not past the vertical centerline?

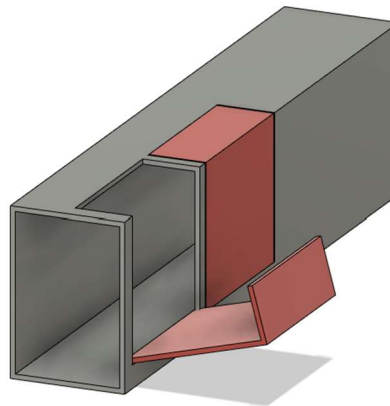

Answer: This configuration meets the hatch requirements.

5. Is the battery that is powering the servos added to the battery capacity for mission 3's scoring equation?

Answer: No, only the propulsion battery capacity is used in the scoring for M3.

6. What is AIAA DBF's method of verifying that the propulsion packs are "commercial off-the-shelf"? Are there any documents / materials that the teams need to provide at tech inspection? Are there multiple ways to show that the batteries are "commercially off-the-shelf"?

Answer: As required in the rules, the manufacturer's label must be on the battery pack and visible for inspection. The Tech Inspectors reserve the right to verify that the manufacturer on the label is a legitimate commercial provider and that the batteries presented are commercially available from the manufacturer (or distributor). Homemade battery packs with a custom label are not allowed.

7. In the parking spot which is 2.5 feet width, is the payload inside the plane?

Answer: When the airplane is in the parking configuration at the start of a mission either in the parking spot for the ground mission or the staging box for a flight mission, the payloads must be outside of the airplane to start the mission as clearly stated in the rules.

8. Is the vertical center line is a line perpendicular to the direction of flight or parallel? And where is the top and bottom positions?

Answer: The vertical centerline is a vertical plane passing through the geometric center of the airplane fuselage and parallel to the longitudinal axis or direction of flight. Top and bottom are the top and bottom surfaces of the fuselage at the vertical centerline location.

9. [Does the] the battery [have] a location constraint in the aircraft?

Answer: No.

10. How can you ensure that every team has a fair chance of packing their passengers to have the same weight and dimensions? And what tolerances/variances, if any, can we expect in the dimensions and weight of the dolls?

Answer: The dolls are commercial off the shelf without tolerances on weight and dimensions provided by the manufacturer. Teams will have to make their own assumptions on tolerances to assure compliance with their designs – that's the nature of COTS hardware.

11. Must the passenger compartment be strictly behind the crew compartment? Can the crew compartment be directly above the passenger compartment and separated by a bulkhead?

Answer: As clearly shown in the rules, Figure 6, the crew compartment must be in front of the passenger compartment.

12. Can the aircraft's RC system be powered on (using the avionics battery) during the ground mission to actuate mechanisms that switches the aircraft between parked and flying configurations? Who is allowed to operate the radio transmitter that controls such mechanisms?

Can hatches be actuated from a remote? If so, who is allowed to control this? Can multiple hatches be actuated by the same mechanism.

Answer: The avionics may be powered on during the ground mission to assist with the conversion from parking to flight configurations and back as well as to test all subsystems at the end of the GM. The operation with the RC transmitter can be by either the pilot or assembly crew member for the GM or the pilot, observer or assembly crew member in the staging box for flight missions. Multiple hatches may be actuated by a single mechanism.

13. Can Motors be swapped out for different missions?

Can We switch propulsion systems between each mission? i.e. can different motors and/or ESCs be used for each mission?

Answer: No. Once an airplane has passed tech inspection, there can be no changes to the configuration unless specifically allowed by the rules for specific payloads and missions.

14. Is it permissible to rotate the aircraft in the staging box prior to the mission so it faces forwards and not sideways as it did in the parking space?

Answer: Location and orientation of the airplane inside the staging box prior to starting the 5-minute assembly time is up to each team to decide.

15. Is this hinge system, illustrated in the provided image, permissible?

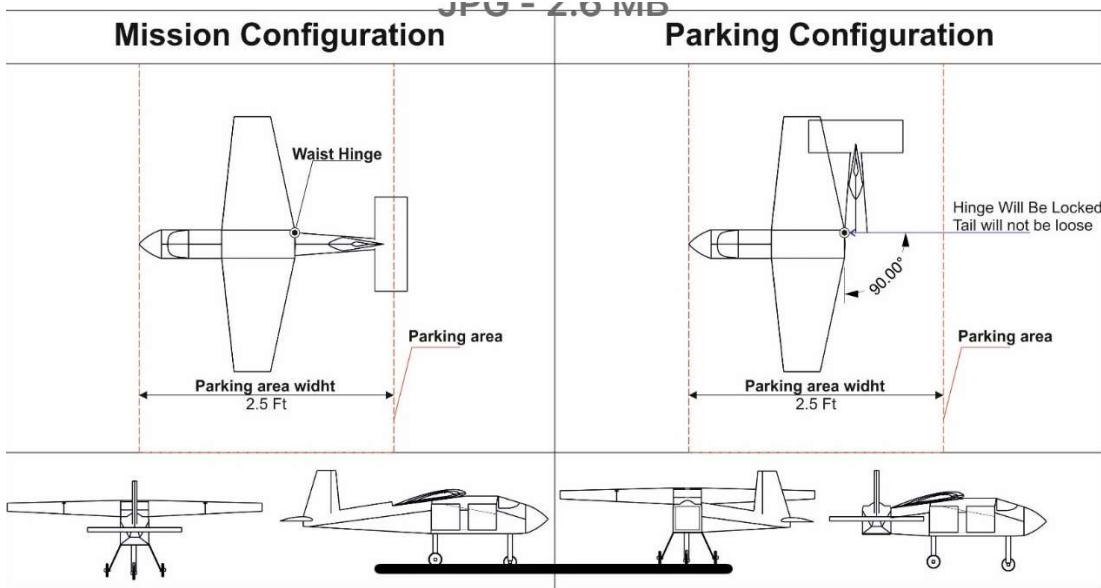

Answer: This is an acceptable method of meeting the parking configuration requirement.

16. Can a ballast be used? Similarly, can a different ballast be configured for each mission configuration?

Answer: Yes, a ballast can be used and it may be different for each mission. However, the ballast must be approved in Tech Inspection to assure it is secured properly and is included in the wing tip test if it is part of the heaviest configuration.

17. At the start of ground mission, if we have wings that fold out electronically after the plane is moved from the parking spot, are we allowed to place passengers into their restraints (outside of the aircraft) while these wings are folding out, and then place them into the aircraft once the wings have completed folding out (i.e. in flight configuration)?

Answer: The airplane must be in the flight configuration before any payload work can be done, including putting the payloads into mission specific inserts.

18. Do winglets' span/height count in the span constraint?

Answer: Winglets are part of the total span.

19. Regarding “The Crew, EMTs, Patients, and Passengers will be provided at the competition,” will the payload passengers be in the same condition as they come from the supplier, or will the surface finish be modified in any way (i.e. painted, sanded, polished)?

Answer: The official contest dolls will be identified with yet to be determined marking, colorization, etc. but the form, fit and function of the dolls will NOT be altered by the identification markings.

20. Regarding “There must be a solid bulkhead between the Crew and Passenger compartment,” and “The bulkhead is only required between the passenger compartment and cockpit [when asked if the nose section must be entirely sealed],” is it acceptable to have a wiring hole pass through the crew bulkhead underneath the floor of the passenger and crew compartments provided that the passenger and crew compartments are still separated by a solid wall (see reference picture)?

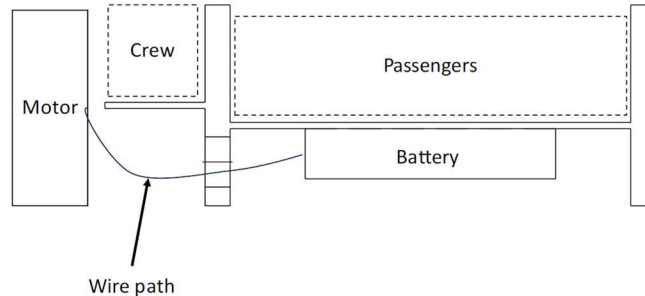

Answer: Yes, as long as it does not pass through the bulkhead separating the crew and passenger compartments.

21. “The Crew shall be in a cockpit such that their heads are above the fuselage forward of the cockpit as shown in Figure 6” Does the nose cone need to have a discernible step down or can we choose a smoother aerodynamic shape?

Answer: The transition of the fuselage forward of the cockpit is up to each team to determine as long as it meets the requirement that it is below the crew heads.

22. “The Crew must be loaded via a separate hinged hatch(es) that is forward of the required bulkhead.” Can this hatch cross the fuselage centerline unlike the passenger hatches?

Answer: There is no restriction on the location of the crew hatch hinge(s).

23. Our team was looking to purchase more crew members to test our aircraft, but upon looking in the rules for the Amazon link, the link no longer works. We understand AIAA and DBF are not responsible for updating the site, but we were hoping you could give us an alternate link for the official competition crew members.

Answer: The wood peg dolls procured for the fly-off are manufactured by Woodpeckers. There is a store within Amazon at the following link:

https://www.amazon.com/stores/page/9E04FA46-9A25-4396-A009-21D32F1043A8?ingress=2&visitId=67d687cf-9af4-4f48-8375-62971852f9ef&ref_=ast_bln

You can also procure directly from the manufacturer at the following link:

<https://woodpeckerscrafts.com/peg-doll-people/>

As noted in Q&A#1, the drawing originally provided on Amazon had an incorrect dimension. The correct dimensions are provided in the Q&A and in the updated rules. The figure is also correct on the Woodpeckers site. It has not been updated on Amazon yet.