

11 February 2010 Update



2009/10 Rules and Vehicle Design

Rules Posting: 17 Aug 2009 - Updated 28 Sept 2009

Entry Deadline: 31 Oct 2009

The contest rules may be augmented/supplemented at any time during the competition. During the period from the rules posting up to the entry deadline the FAQ will be used to document any changes.

Following the entry deadline changes will be e-mailed to each teams contact e-mail address. Questions may be submitted at any time, answers will be provided ONLY as outlined above.

Rules are not FINAL until 31 Oct Entry Deadline

Summary:

The AIAA through the Applied Aerodynamics, Aircraft Design, Design Engineering and Flight Test Technical Committees and the AIAA Foundation invites all university students to participate in the **Cessna Aircraft Company/Raytheon Missile Systems - Student Design/Build/Fly Competition**. The contest will provide a real-world aircraft design experience for engineering students by giving them the opportunity to validate their analytic studies.

Student teams will design, fabricate, and demonstrate the flight capabilities of an unmanned, electric powered, radio controlled aircraft that can best meet the specified mission profile. The goal is a balanced design possessing good demonstrated flight handling qualities and practical and affordable manufacturing requirements while providing a high vehicle performance.

To encourage innovation and maintain a fresh design challenge for each new year, the design requirements and performance objectives will be updated for each new contest year. The changes will provide new design requirements and opportunities, while allowing for application of technology developed by the teams from prior years.

Check the rules package carefully as items and approaches that were legal in past years may not be legal for this contest year. Only the contents of this Rules package, the 2009/10 FAQ, and 2009/10 Q&A documents hold bearing on the requirements and/or allowances for the current contest year. It is the responsibility of the teams to know and follow all provided rules, the FAQ, and all contest day briefings.

Questions may be addressed to the contest director as outlined in the communications section below.

Cash prizes are \$2500 for 1st, \$1500 for 2nd and \$1000 for 3rd place. The winning team will be invited to present their design at the AIAA/U.S. Air Force T&E Days conference.

Judging:

Students must design, document, fabricate, and demonstrate the aircraft they determine to be capable of achieving the highest score on the specified mission profile(s). Flight scores will be based on the demonstrated mission performance obtained during the contest.

Each team must also submit a written Design Report. A maximum of 100 points will be awarded for the team design report. Scores for the written reports will be announced at the beginning of the fly-off.

The overall team score is a combination of the Design Report and Flight scores. The team with the highest overall team score will be declared the winner.

Scores will be FINAL 7 working days after the completion of the contest. This period will allow for review of the scores in a timely fashion following the contest.

All submitted reports are the property of AIAA, Cessna and Raytheon and may be published or reproduced at their discretion.

Contest Site:

Host for the competition will be Cessna Aircraft Company. The fly-off is planned to be held near their facilities in Wichita, KS. You can check on historical weather conditions at www.weatherbase.com or www.weatherunderground.com.

Team Requirements:

All team members (except for a non-student pilot) must be full time students at an accredited University or College and student members of the AIAA. At least 1/3 of the team members must consist of Freshman, Sophomores or Juniors. The pilot must be an AMA (Academy of Model Aeronautics) member. Teams may use a non-university member for the pilot if desired. We will also provide qualified pilots on the contest day for any teams who are unable to have their pilot attend.

There may be a maximum of two (2) teams entered from any one educational institution. For schools with multiple campuses in different cities/parts of the state, each campus will be considered as a separate entity.

Past Year Reports:

Winning team design reports from prior contest years are posted on the contest website as examples. Note that the formatting and content has evolved from one year to the next. Only the rules noted in this document apply for the current year. The top scoring report(s) from this year's contest will be placed on the contest web site for the next year's competition.

Sponsorship:

Teams may solicit and accept sponsorship in the form of funds or materials and components from commercial organizations. All **design, analysis and fabrication** of the contest entry is the sole responsibility of the student team members.

Schedule:

A completed electronic entry must be **RECEIVED** by the contest administrator by 5 PM US East Coast Time on **31 October 2009**. Entry forms may not be submitted before 1 October.

Note: The DBF entry form is different from the one used for other AIAA student competitions. The DBF entry form is a MS-Word file and can be found on the contest web site. It must be submitted by e-mail to the contest administrator at director@aiaadb.org. Be sure to include the Phone and FAX number for your team advisor and

at least one student contact so we may reach you in case of any last minute problems or changes. All teams are required to provide two point-of-contact e-mail addresses with their contest application, one of which must be the teams advisor. *It is the teams responsibility to make sure the e-mail contact addresses they supply remain active during the entire period from entry to the close of the competition, as e-mail will be the primary means to provide information and updates. Do not use an internal team correspondence e-mail list server as your point of contact e-mail address.*

Please Note: The *Entry Name* may not be changed once the form is submitted, but must be retained and used on all reports and correspondence during the competition year.

Design reports must **ARRIVE** at the Chief of Scoring address by 5 pm local time (at the report delivery address) on **2 March 2010**. Reports will be judged "as received", no corrections/additions/page changes will be made by the organizers so check your reports carefully before sending them. **Teams must submit 5 hard copies of the report (printing details are outlined in the report section at the bottom of this document) AND one electronic copy in PDF. Only the hard copies will be used for judging.**

The contest is scheduled for **16-18 April 2010**. The competition will run from Noon to 5PM on Friday, and 8AM to 5PM on Saturday and Sunday. Final awards will be presented at the end of Sunday's competition. All teams should plan their travel so that they may stay for the awards presentations on Sunday.

Please note that tech inspections will be available on Friday **16 April**. All teams are encouraged to be prepared to have your plane inspected on Friday. Inspections will also be available on Saturday, but waiting until Saturday to go through tech may mean that your team will miss one or more rounds through the flight sequence. If we have a full turnout you may not be able to get in a full set of scoring flights unless you are "ready to fly" at every opportunity.

Note: All schedule deadlines are strictly enforced.

Late entries will NOT be accepted. Late report submissions will NOT be judged. Teams who do not submit the required written reports will NOT be allowed to fly. It is the team's responsibility to assure that all deadlines are know, understood and met.

Communications:

Update: The AIAA mail servers will not send e-mail to @hotmail.com addresses. Do NOT use a hotmail address for any of your team contacts or e-mail. (31Oct2009)

The contest administration will maintain a World Wide Web site containing the latest information regarding the contest schedules, rules, and participating teams. The contest web site is located at:

<http://www.aiaadb.org>

Questions regarding the contest, schedules, or rules interpretation may be sent to the contest administrator by e-mail at:

director@aiaadb.org

Questions received prior to the official entry submission date will not be answered directly. Select questions "may" be answered in the FAQ prior to the entry submission date. Official questions and answers received following the entry submission date will be provided by e-mail to all teams of record.

Written reports should be sent to the Chief of Scoring at:

AIAA Design/Build/Fly Contest/Report Judging
David Levy
Cessna Aircraft Company

MS PAW
5701 E. Pawnee
Wichita, KS 67218
316-831-2014
316-206-6674 FAX

Aircraft Requirements - General

- ε The aircraft may be of any configuration except rotary wing or lighter-than-air.
- ε No structure/components may be dropped from the aircraft during flight.
- ε No form of externally assisted take-off is allowed. All energy for take-off must come from the on-board propulsion battery pack(s).
- ε Must be propeller driven and electric powered with an unmodified over-the-counter model electric motor. May use multiple motors and/or propellers. May be direct drive or with gear or belt reduction.
- ε Motors may be any commercial brush or brushless electric motor.
- ε For safety, each aircraft will use a commercially produced propeller/blades. Must use a commercially available propeller hub/pitch mechanism. Teams may modify the propeller diameter by clipping the tip, and may paint the blades to balance the propeller. No other modifications to the propeller are allowed. Commercial ducted fan units are allowed.
- ε Motors and batteries will be limited to a maximum of 40 Amp current draw by means of a 40 Amp fuse (per motor or battery pack) in the line from the positive battery terminal to the motor controller. Only ATO or blade style plastic fuses may be used. (e.g. "Maxi" size Slow Blow, 1.15"x0.85". Available online www.Mcmaster.com part #7460K51)
- ε Must use over the counter NiCad or NiMH batteries. For safety, battery packs must have shrink-wrap or other protection over all electrical contact points. The individual cells must be commercially available, and the manufacturers label must be readable/documented (i.e. clear shrink wrap preferred). All battery disconnects must be "fully insulated" style connectors.
- ε **Maximum propulsion battery pack weight is defined in the mission rules section.** This battery pack must power propulsion systems only. Radio Rx and servos MUST be on a separate battery pack. Batteries may not be changed or charged between sorties during a flight period.
- ε Aircraft and pilot must be AMA legal. This means that the aircraft TOGW (take-off gross weight with payload) must be less than 55-lb, and the pilot must be a member of the AMA.
- ε Since this is an AMA sanctioned event, the team must submit proof that the aircraft has been flown prior to the contest date (in flight photo) to the technical inspection team. Contest supplied qualified pilots will be available to teams who require them.

Aircraft Requirements - Safety

All vehicles will undergo a safety inspection by a designated contest safety inspector prior to being allowed to make any competition or non-competition (i.e. practice) flight. All decisions of the safety inspector are final. Safety inspections will include the following as a minimum.

- Physical inspection of vehicle to insure structural integrity.
 1. Verify all components adequately secured to vehicle. Verify all fasteners tight and have either safety wire, locktite (fluid) or nylock nuts. Clevises on flight controls must have an appropriate safety device to prevent their disengaging in flight.

2. Verify propeller structural and attachment integrity.
 3. Visual inspection of all electronic wiring to assure adequate wire gauges and connectors in use.
 4. Radio range check, motor off and motor on.
 5. Verify all controls move in the proper sense.
 6. Check general integrity of the payload system.
- Structural verification. All aircraft will be lifted with one lift point at each wing tip to verify adequate wing strength (this is "roughly" equivalent to a 2.5g load case) and to check for vehicle cg location. Teams must mark the expected empty and loaded cg locations on the exterior of the aircraft. Special provisions will be made at the time of the contest for aircraft whose cg does not fall within the wing tip chord. This test will be made with the aircraft filled to its maximum payload capacity.
 - Radio fail-safe check. All aircraft radios must have a fail-safe mode that is automatically selected during loss of transmit signal. The fail-safe will be demonstrated on the ground by switching off the transmit radio. During fail safe the aircraft receiver must select:

Throttle closed
Full up elevator
Full right rudder
Full right (or left) aileron
Full Flaps down (if so equipped)

The radio Fail Safe provisions will be strictly enforced.

- All aircraft must have a mechanical motor arming system separate from the onboard radio Rx switch. This **MUST** be the contest specified "blade" style fuse. This device must be located so it is accessible by a crewmember standing **ahead** of the propeller(s) for pusher aircraft, and standing **behind** the propeller(s) for tractor aircraft (i.e. the crew member must not reach across the propeller plane to access the fuse). The "Safety Arming Device" will be in "Safe" mode for all payload changes. The aircraft Rx should always be powered on and the throttle verified to be "closed" before activating the motor arming switch. Fuses **MUST be mounted on the outside the aircraft** (they can not be behind an access panel or door) and **MUST** act as the "safeing" device.

Note: The aircraft must be "safed" (arming fuse removed) any time the aircraft is being manually moved, or while loading/unloading payload during the mission. The arming fuse must be removed anytime the aircraft is in the hanger area.

Scoring:

In the event that, due to time or facility limitations, it is not possible to allow all teams to have the maximum number of flight attempts, the contest committee reserves the right to ration and/or schedule flights. The exact determination of how to ration flights will be made on the contest day based on the number of entries, weather, and field conditions.

Each team's overall score will be computed from their **Written Report Score and Total Flight Score** using the formula:

$$\text{SCORE} = \text{Written Report Score} * \text{Total Flight Score}$$

The total flight score is the sum of the individual mission flight scores.

Mission Task Matrix:

Baseball Team Plane

General:

- Battery packs must weigh less than **4** lbs

- ε Teams will be allowed a maximum of **5** flight attempts or **4** successful scoring flights whichever comes first.
- ε All flight hardware must fit in a 2'x2'x4' **Case**.
 - ν The case must include everything the team brings to the staging area. This includes the aircraft, radio Transmitter, safety fuse(s) and tools. If you forget something you must leave the staging area and forfeit the flight attempt.
 - ν The case will be checked for size by placing it inside a contest supplied "baggage checker" each time the team enters the staging area for a flight attempt. There are no exceptions to the **Case** fitting in the baggage checker for handles, hinges, screw heads, or other protrusions.
 - ν The case can be constructed of any means or materials but it must not sustain damage/tears during the missions or the flight attempt will be forfeited.
 - ν The case may **NOT** use tape, magnets, or Velcro in any way.
- ε The aircraft may **NOT** use tape, magnets or Velcro in any way with the following specific exceptions:
 - ν Velcro may be used to secure the motor speed controller
 - ν Velcro may be used to secure the flight and receiver batteries.
- ε All payloads must be secured sufficiently to assure no movement of payload elements or variation of aircraft cg during flight. The payload restraints may **NOT** use tape, magnets or Velcro in any way.
- ε Assembly crew and ground crew size is limited to 3 people.
- ε **All payloads for this years contest will be provided by the contest administration.**
- ε "**Bats**" will be between 26 and 30 inches long and weigh between 16 and 20 ounces. Bats will have a nominal diameter of 2". Bats will not be tapered. Each Bat will have a 3/16 inch hole located at the cg. The team's bat mounting system **MUST** include a pin that registers in the hole to assure the bat can not slide in the mount along it's length. Bat mounting systems must securely restrain the Bat in all six degrees of freedom.
- ε "**Softballs**" will be ASA Girls Fast Pitch 11" (reference circumference) and 12" (reference circumference) Softballs.

Mission Sequence:

- ε The fully loaded and secured **Case** will be weighed each time the team enters the staging area for a flight. **ALL** mission scores will use a single weight value which will be the heaviest weight recorded on any flight attempt made by the team during the contest weekend.
- ε After entering the staging area the team will assemble and flight check their aircraft prior to being called to the flight line.
 - ν The assembly and checkout must be completed in less than 5 minutes.
 - ν The team may not work on the aircraft after the 5 minute assembly and checkout time.
 - ν Only the assembly crew, pilot and pilot assistant may be in the staging area during the assembly.
 - ν After the assembly is complete the members of the assembly crew may be swapped for members of the ground crew (if different).
- ε When called to the flight line the team must bring the aircraft and case to the designated areas.
- ε Once at the flight line the Mission will be selected.
 - ν Missions will be flown in order. A new mission can not be flown until the team has obtained a successful score for the preceding mission(s). A repeat of a previously successful mission can be flown in any order.
 - ν **Total Flight Score** will be the sum of the teams best score for each mission, Mission #1, Mission #2, and Mission #3

Missions:

- ε Individual mission scores (Mission #1 and Mission #2) will be factored by the weight of the complete flight system in it's **Case**.

- ε The weight scoring factor $W_1 = W_{ref}/W_{team}$ where W_{ref} is the lightest weight recorded for any team that successfully completes Mission #1 and W_{team} is the heaviest weight recorded for that team from **ANY** mission attempt.
- ε The weight scoring factor $W_2 = W_{ref}/W_{team}$ where W_{ref} is the lightest weight recorded for any team that successfully completes Mission #2 and W_{team} is the heaviest weight recorded for that team from **ANY** mission attempt..
- ε Take-off distance for all missions is 100 ft.
All wheels must be off the runway, and remain off the runway, by the marked take-off line.
- ε The aircraft must complete a successful landing at the end of a mission for the mission to receive a score.
A successful landing is outlined in the general mission specification section below.
- ε **Mission 1**
 - 2 Lap ferry flight
 - Mission score $M1 = T_1 * W_1 * 50$.
 - $T_1 = t_{ref}/t_{team}$ where t_{ref} is the lowest time recorded for any team that successfully completes mission #1 and t_{team} is the mission #1 time recorded for that team.
 - Flight time is from start of take-off (advancing the throttle) to completion of the second lap
 - Second lap is complete when the aircraft passes over the start/finish line while still in the air
- ε **Mission 2**
 - 3 Lap payload flight.
 - Payload will be a random selection of from 6 to 10 Softballs.
Teams will roll dice until getting a number between 6 and 10.
They will then select the required number of balls from a blind bag, place them inside their **Case**
 - **Note: The aircraft will not be inside the case when it is holding the Softball payload..**
 - Softballs will be supplied by the contest and will be a random mix of 11" and 12" sizes
 - Softballs must be carried internal to the aircraft. Softballs must form a grid pattern and may not be staggered (overlapped).
 - Mission score $M2 = T_2 * W_2 * 100$.
 - $T_2 = t_{ref}/t_{team}$ where t_{ref} is the lowest time recorded for any team that successfully completes mission #2 and t_{team} is the mission #2 time recorded for that team.
 - The aircraft will be "safed" (fuse removed) during the loading.
 - Time will begin with the aircraft on the start/finish line and the payload placed inside the teams **Case** and the **Case** closed.
 - Time will end when the team has finished loading the aircraft, closed the case, returned to the designated loading crew area, and calls "Stop".
 - After loading, the aircraft must start the flight portion of the mission with no additional team interaction other than installing the safety fuse and positioning the aircraft on the starting line.
- ε **Mission 3**
 - 3 Lap payload flight
 - Payload will be a random mix of "Bats".
 - Bats will be supplied by the contest and will be of varied length and weight.
 - Bats must be carried external to the aircraft.
 - The number of "Bats" to be carried on the mission will be chosen by the team and may vary for each mission attempt.
 - Mission score $M3 = T_3 * F_{bats} * 100$.
 - $T_3 = t_{ref}/t_{team}$ where t_{ref} is the lowest time recorded for any team that successfully completes mission #3 and t_{team} is the mission #3 time recorded for that team.
 - $F_{bats} = N_{bats_team}/N_{bats_ref}$ where N_{bats_ref} is the largest number of bats carried by any team that successfully completes mission #3 and N_{bats_team} is the number of bats carried by the team on that flight attempt.
 N_{bats} must be at least 1 and no more than 5.
 - Loading of the bats is not timed. The aircraft will be "safed" (fuse removed) during the loading.
 - Flight time is from start of take-off (advancing the throttle) to completion of the third lap
 - Third lap is complete when the aircraft passes over the start/finish line while still in the air

Flight Line Order:

- ε A flight order list will be generated and posted at the beginning of flying on Saturday. Teams will always rotate in this order. The flight order will be repeated continuously. The flight order list will carry over from Saturday to Sunday at what ever spot in the rotation it leaves off.
- ε Each team's position in the flight order will be determined from their written report score, highest report score goes first.
- ε There will be four *staging box* positions near the flight line. While in the *staging box* teams can make any final preparations and checkout required prior to flight.
- ε If you are not in place in a *staging box* when your rotation number comes up you will miss your opportunity for that rotation.
Note: We will not call teams to the *staging box*, it is the teams responsibility to monitor the progress of the contest and decide when they need to get ready to enter an open spot in the *staging box*. A contest official will be available to help teams in entering the *staging box* area.
- ε Electing to enter one of the *staging box* positions on your turn in the rotation order **will constitute using a flight attempt**.
 If you choose to leave the *staging box* for any reason you will **forfeit that flight attempt**.
 If you go to the flight line and are not able to begin your takeoff when instructed you will **forfeit that flight attempt**.

General Mission Specification and Notes:

- ε The aircraft propulsion system(s) must be "safed" (fuse removed) during any time when crew members are preparing/handling the aircraft.
- ε Maximum flight support crew is: pilot, observer, and 3 ground crew.
 Only the designated ground crew may load the aircraft payload. Pilot and observer may be members of the ground crew, provided total ground crew size remains 3 people.
- ε Observer and all ground crew must be students. **Only the pilot may be a non-student.**
- ε The upwind turn will be made after passing the upwind marker. The downwind turn will be made after passing the downwind marker. Upwind and downwind markers will be 500 ft from the starting line. Aircraft must be "straight and level" when passing the turn marker before initiating a turn.
- ε Aircraft must land on the paved portion of the runway. Aircraft may "run-off" the runway during roll-out. Aircraft may not "bounce" off the runway.
- ε After landing, aircraft will return to the starting line as outlined in the individual mission specifications.
Aircraft obtaining "significant" damage during landing will not receive a score for that flight. Determination of "significant" is solely at the discretion of the Flight Line Judge.
- ε Flight altitude must be sufficient for safe terrain clearance and low enough to maintain good visual contact with the aircraft. Decisions on safe flight altitude will be at the discretion of the Flight Line Judge and all rulings will be final.

Additional information is included in the [FAQ](#) (Frequently Asked Questions).

Flight Course:

The orientation (direction) of the flight course will be adjusted based on the prevailing winds as determined by the Flight Line Judge. The flight course will be positioned to maintain the greatest possible safety to personnel and facilities. The nominal flight course is shown in the Figure below.

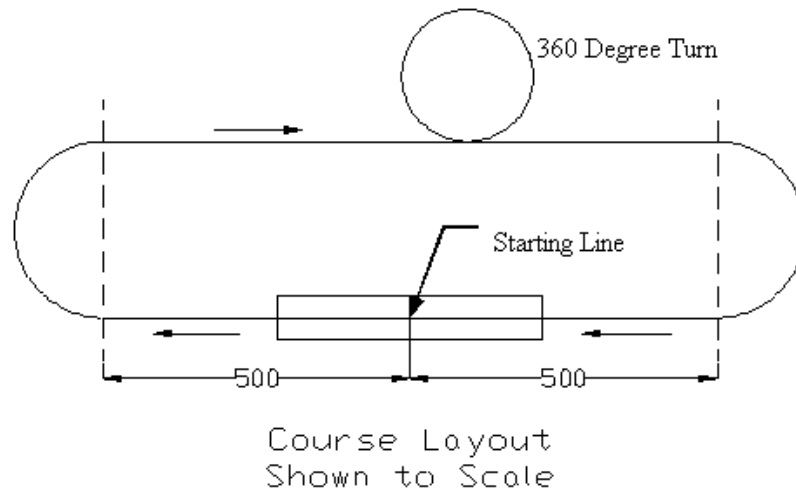

Protest Procedure:

Submitting a protest is a serious matter and will be treated as such. Teams may submit a protest to the Contest Administration at any time during the competition. Protests may not be submitted after the conclusion of the competition. Protests must be submitted in writing and signed by the team advisor, designees are not allowed for protest submissions. If the team advisor is not present, he may FAX a signed protest to the team for them to present. Protests may be posted for review at the decision of the administration.

Protests and penalties (up to disqualification from the contest for deliberate attempts to misinform officials, violate the contest rules, or safety infractions) will be decided by the Contest Administration. The decision of the Contest Administration is final.

Design Report:

Each team will submit a judged design report as outlined below and in the **SCHEDULE** section above.

Note: Reports must strictly adhere to the following requirements. Failure to meet requirements will result penalties that range from score reduction to elimination from the contest.

- ⊃ Reports must have the University and Team name (as listed on the ORIGINAL entry form, not team “nicknames”) on the cover page.
Reports missing this identification information will not be scored.
- ⊃ Reports must be bound. Simple spiral bindings are sufficient and preferred. Paper clips, 3-ring binders, or clamps are **NOT allowed**.
Stapled reports will be *penalized 10 points*
Unbound reports will not be scored.
- ⊃ Report paper may be no larger than 8 ½ inches wide by 11 inches long with the exception of the drawing package.
A4 paper may be used **ONLY** if it is cut to a maximum length of 11 inches.
The drawing package may be on 11 inch long x maximum of 17 inch wide pages.
A 10 point penalty will be given for the use of oversize paper.
- ⊃ Absolute maximum page count for the report is **60 pages**, inclusive of all pages of any type including any form of front and back cover.
For reports printed as double sided, blank back-sides of pages **WILL** be included in the page count with the specific exceptions of:

- 1) the back side of the very first page or cover;
- 2) the back side of the very last page or cover;
- 3) the back side of 11 inch x 17 inch size drawing pages.

Reports exceeding the maximum page count will be given a 10 point penalty for each additional page.

- ε Reports will be scored on a 100 point basis following the guidelines outlined below.
All information used for scoring **must be in the outlined sections, content that is out of sequence, including the drawing package, will be treated as missing** and scored accordingly.
- ε All reports should be at least one and one half line spacing, 10-pt Arial font. Tables and figures will also be at least 10-pt Arial font. Margins should be at least 1 inch on all sides. All figures and tables should be clear and readable for the judges. The reports will be judged on format and readability.
- ε **ALL** items requested below should be present, easy to locate and identify, well documented and in the correct section for full scoring.
- ε Examples of winning team design reports from prior contest years are posted on the contest website. Note that the formatting and content has changed from one year to the next. Prior year reports may not reflect or meet the rules listed for the current year.
- ε Report scores will not be available prior to the contest weekend.

Note:

Protective pages (clear or otherwise) are not required and are a waste of money.

Reports are very durable. Please ship in envelopes. Boxes and bubble wrap are not required. We're going to ship them to the judges in envelopes. You won't be penalized if the shipper tears a cover. Remember. We throw them away when we're done.

Do Not Use Styrofoam Peanuts!!!

Do not ask for confirmation of receipt. Documentation to prove that your reports were shipped with guaranteed delivery by the deadline and proof that your email was sent well before the deadline are all that's required to prevent disqualification.

Report scoring is based on the reports AS SUBMITTED. Final proofing of the report printed copies (ALL) prior to submission is STRONGLY encouraged.

Design Report

All section scores will include format, completeness and readability

1. Executive Summary: (10 points):
 - ... Provide a summary description of your selected design and why it is the best solution to the specified mission requirements.
 - ... Describe your key mission requirements and design features keyed to those requirements.
 - ... Document the performance/capabilities of your system solution.
2. Management Summary (5 points):
 - ... Describe the organization of the design team.
 - ... Provide a chart of design personnel and assignment areas.
 - ... Provide a milestone chart showing planned and actual timing of the design / fabrication / testing processes.
3. Conceptual Design (15 points):
 - ... Describe mission requirements (problem statement).
 - ... Translate mission requirements into design requirements.
 - ... Review solution concepts/configurations considered.
 - ... Describe concept weighting, selection process and results.
4. Preliminary Design (20 points):
 - ... Describe design/analysis methodology

- ... Document design/sizing trades
 - ... Describe/document mission model (capabilities and uncertainties)
 - ... Provide estimates of the aircraft lift, drag and stability characteristics.
 - ... Provide estimates of the aircraft mission performance.
5. Detail Design (30 points total. 15 points for discussion items, 15 points for drawing package):
- ... Document dimensional parameters of final design.
 - ... Document structural characteristics/capabilities of final design.
 - ... Document systems and sub-systems design/component selection/integration/architecture.
 - ... Document Weight and Balance for final design. Must include a Weight & Balance table for the empty aircraft and with each of the possible payloads
 - ... Document **flight** performance parameters for final design.
 - ... Document **mission** performance for final design.
- Drawing Package
- ... 3-View drawing with dimensions.
 - ... Structural arrangement drawing.
 - ... Systems layout/location drawing.
 - ... Payload(s) accommodation drawing(s).
6. Manufacturing Plan and processes (5 points):
- ... Document the process selected for manufacture of major components and assemblies of the final design.
 - ... Detail the manufacturing processes investigated and the selection process/results.
 - ... Include a manufacturing milestone chart showing scheduled and actual event timings.
7. Testing Plan (5 points):
- ... Detail testing objectives, schedules, and check-lists.
8. Performance Results (10 points):
- ... Describe the **demonstrated** performance of key subsystems and compare it to predictions from Section 5. Explain any differences and improvements made.
 - ... Describe the **demonstrated** performance of your complete aircraft solution and compare it to predictions from Section 5. Explain any differences and improvements made.

Design Report Electronic Copy

Each team must provide an electronic copy of their final design report in addition to the hard copies used for the report judging as outlined below.

- ⌘ Electronic copy must be **RECEIVED** by the same deadline as listed above for the written reports.
- ⌘ Electronic report files must be named: “**2010DBF** *[university]* *[team name]*.PDF”
- ⌘ Electronic report must be a single file with all figures/drawings included in the proper report sequence in PDF format.
(Free PDF file conversion programs are available on the Internet, such as www.pdf995.com.)
- ⌘ Electronic reports should have all figures compressed to print resolution to minimize file size.
- ⌘ Electronic reports must be less than **20 MB** in size (including encoding for e-mail transmission) and e-mailed to: designbuildfly@gmail.com.

[\[AIAA Student Design/Build/Fly Competition homepage\]](#) [\[AIAA Homepage\]](#)

18 October 2009 Update



Frequently Asked Questions (FAQ) 2009/10 Competition Specific

Please check the FAQ often during the competition. Please note that rules interpretation questions are not answered by e-mail until after the end date (when all participant e-mail address are known), so that all teams will have equal access to all rules information.

***** All Rulings In This FAQ Supplement The Official Rules! *****

General Notes:

- ⌘ 2.4 GHz ISM band radios are now legal for the contest. They MUST be capable of implementing the full fail-safe sequence procedure outlined in the rules. If you are going to use a 2.4 GHz radio please note it in the appropriate location on the entry form.
- ⌘ Brushless motors are now legal.
- ⌘ Ni-mH batteries are now legal. Li-Poly batteries are NOT legal for use either as propulsion or RC batteries.

Payload Questions:

**** Payload Information in "Rules" document updated 28 Sep 09 ****

All payloads for this year will be provided by the Contest

1. **Question:** Is it possible to alter the aircraft after rolling the dice and the number of softballs to be carried is known??
Answer: Any reconfiguration of the payload bay and restraint system must be done during the timed portion of the mission.
2. **Question:** When the rules state, "a random mix of 11" and 12" sizes," does this refer to the softball size of 11" & 12" in *circumference*?
Answer: The softballs will be standard competition softballs. An "11 inch" softball has a nominally 11 inch circumference, not diameter.
3. **Question:** Can the softball grid pattern be vertical or just horizontal?
Answer: The grid pattern can be vertical, horizontal, or both.
4. **Question:** Can teams use one or more inserts (aka speed loaders) for the different softball payloads?
Answer: You may use different inserts for different combinations of the softball payload. All inserts must be included in the Case for the system weight. Inserts may be in the Case or in the aircraft prior to the start of timed loading, but you may not change inserts in either the Case or the aircraft once you have entered the competition area and before rolling the dice to determine the number or combination of softballs to be flown. The inserts must not hold/contain the softballs when in the Case. Inserts can only be loaded/contain the softballs after the start of the timed loading.
5. **Question:** Are there any constraints on the shape of the Case other than the size limits?
Answer: The Case can be any shape, it need not be a single rectangular block. However, it must be a "Case", rigid and able to hold it's own shape full and the same shape when empty, it can not be a "bag" or other collapsing structure.
6. **Question:** Can the aircraft be designed to hold less than the maximum 10 softballs?
Answer: No, it must be capable of holding the full softball payload. Teams may select what they consider as a full bat payload.
7. **Question:** Will the pin hole in the bats go completely through allowing a through-bolt for a bat retainer?
Answer: The alignment pin hole will not go completely through the bats. The alignment pin is not intended to be part of the retention system, but is a safety feature to prevent the bat from slipping out of the retention system or sliding fore/aft during flight upsetting the aircraft cg location.

Flight / Mission Questions

1. **Question:** Do we have to fly all of the different missions to get a score?
Answer: You will get a score for each mission you successfully complete. The flights must be completed in the order specified to obtain a score.
2. **Question:** Do we have to use the same plane for each mission?
Answer: You must use a single plane for the entire contest weekend.
3. **Question:** Is it permitted to add/remove necessary/unnecessary components to/from the aircraft to perform the different flight missions?
Answer: You may change internal (payload bay) components between missions, such as adjusting the ball restraint system components. All external portions of the aircraft must remain the same for all missions.
4. **Question:** How big is the starting line where the aircraft has to come to a stop at? How close does the aircraft have to stop to the line? If it is a line, will the main gear have to be on line or does just some part of the aircraft have to be on top of the line?
Answer: The main gear must be on or ahead of the starting line at the start of each take-off.
5. **Question:** What constitutes a successful landing?
Answer: The aircraft must touch down ON the runway. It may roll, not bounce, off the runway after touchdown.
6. **Question:** Is there a minimum altitude for flying the course?
Answer: No. Altitude must be high enough for safe flight as set by the discretion of the Contest Director.
7. **Question:** Can we tailor the configuration of the aircraft differently for the different missions? For example, could we use different sized propulsion systems for each flight?

Answer: You cannot change the hardware configuration of the aircraft for the different missions. You can however change the propeller diameter/pi for each flight attempt.

8. **Question:** What would constitute “non-critical” versus “significant damage” on landing as described in the rules?

Answer: The decision will be at the discretion of the flight line judges. In general, “non-critical” damage would allow the aircraft to be easily return to safe flight status. A couple of examples of “non-critical” damage would be a broken propeller, bent landing gear, sheared nylon bolts or minor scratches to the finish. If any component is structurally damaged and would be considered a hazard to safe flight then it will be considered as “significant damage”.

9. **Question:** At what wind speed will the contest be called.

Answer: It will be up to each team to determine whether they want to fly or not. The contest will be called if the wind speed exceeds 30 mph for a period of time sufficient to prevent all teams who are ready to fly from being assigned a flight time slot. The 30 mph limit is consistent with normal AMA competitions and is required to retain our contest insurance coverage.

Aircraft Configuration Questions

1. **Question:** On the webpage it states that aircraft CANNOT be of rotary wing design. Rotary wing being somewhat defined in another section as 'vertical flight capability'. However, thrust vectoring IS allowed, as are ducted-fan units. Is vertical Take-off via ducted-fan units legal, or does that fall under the rotary aircraft definition?

Answer: A ducted fan configuration capable of thrust vectoring for short take-off but not true vertical flight would be legal.

2. **Questions:** Can there be thrust vectoring via rotating the engine, nozzles, blown surfaces etc.?

Answer: Yes. Any of the above options is allowed, and may be varied during flight. However, "rotary wing" vehicles are not allowed, so you may need to consult the judges with your specific design doesn't cross over the line into vertical flight capability.

3. **Question:** We have talked with an outside vendor and they possess a *manufacturing* technique that we are not capable of producing here at the school. The design of the part would be done by us, with *manufacturing* done by them.. Is this permitted by the rules?

Answer: No. The rules (sponsor section) say “All design, analysis and fabrication of the contest entry is the sole responsibility of the student team members.” Commercial components may be used if part of the manufacturer's public product line.

4. **Question:** Our team has completed our design calculations and we have found a manufacturer that carries wing *components* that will meet our design criteria. Can we purchase *components* (i.e. foam cores and skins) to construct the wing for our UAV, or are we required to build it from scratch? If our school does not have machining capabilities can we have a vendor laser cut our ribs and formers or machine our original design molds?

Answer: You may use *unassembled components* such as wing cores providing they are integrated in a way that results in the final configuration being an original design. You may also have *components* of your design machined to your design specifications by an outside contractor if the team and/or university does not have the required machining facilities. You may have molds machined for composite parts, but the team must make the actual parts themselves.

5. **Question:** Are gyros legal for stability purposes?

Answer: Yes

6. **Question:** Do the external fuse accessibility requirements (from behind if tractor, from the front if pusher) exclude the use of a pusher-puller type motor engine configuration?

Answer: You may use a push-pull configuration but must locate the fuse(s) such that they can be accessed by the crew member without having to reach over or around either propeller or being in the propeller disk plane of either propeller.

7. **Question:** Does the propulsion battery have to be a single unit (with all cells physically and electrically connected) or can it consist of separate packs

Answer: You may use multiple battery “packs” to power either multiple or a single motor(s) provided the total weight of all packs flown as a set meet the rules requirement. Any/all packs/motors must be fused such that no single battery or motor can exceed the maximum current requirement. If it requires multiple fuses to meet the current protection requirement, then **ALL** fuses must be removed whenever you are required to “safe” the aircraft system.

8. **Question:** If we have multiple battery packs, is the 40 amp fuse meant for each individual battery pack or is maximum amperage of each motor limit to 40 amps.

Answer: The location and number of required fuses will vary depending on your individual aircraft configuration. Fuse(s) must be configured such that no component in the propulsion system, any battery pack and/or any motor, can exceed 40 amps.

Report Questions

Report format rules are significantly changed from prior years. Be sure to follow the current rules. Being allowed in prior years is not grounds for expecting the same item to be allowed this year.

1. **Question:**

Answer:

General Questions

1. **Question:** Is it safe to assume that if the rules do not explicitly forbid something, it is allowed?

Answer: The rules are intentionally designed to not impose too many limitations while allowing each team an equal chance. If something adheres to the “spirit” of the rules it is likely to be allowed. **If you have any specific questions you would like clarified** they may be addressed in a private e-mail to the contest administrator. Ideas will not be disclosed to other teams if they represent a legal and innovative approach. If it is deemed to be not legal, it may be added to this FAQ or posted to the other teams at the administrator's discretion.

2. **Question:** Regarding the test flight photo, does this photo have to be submitted with the report, or just brought to the competition?

Answer: The photo must be shown to the judges during the technical inspection. We will not have copies of the reports available at the contest, so if you want to use a photo in your report you must bring your own copy.

3. **Question:** Can we use LiPo batteries in our transmitter?

Answer: No.

4. **Question:** Are the transmitter and receiver allowed to be store bought?

Answer: The transmitter and receiver **MUST** be a commercial FCC approved system. No modifications to the transmitter (or it's case) or the receiver (or it's case) are allowed.

5. **Question:** Do all of the team members need to be student members of AIAA?

Answer: Since the DBF is part of the AIAA competitions sanctioned by the Student Activities Committee and the AIAA Foundation, all team members should be student members of the AIAA.

6. **Question:** What was the maximum number of people that can make-up a team.

Answer: There is no specific limit on team size. It is up to the team itself to determine a size sufficient to meet the required tasks and small enough to

remain manageable. It is expected most teams would fall in the 5 to 10 member size range, but this is only an estimated guideline.

There is a maximum size of the flight crew (pilot and assistant) and ground crew (3) for this years competition. Please see the RULES section for more details on the limitations on the flight and ground crews.

7. **Question:** Is it necessary to list all team members on the entry.
Answer: Yes, we need to know all the team members to verify the under/upper classmen rule. Teams will be allowed to revise/update their official membership one time in February.
8. **Question:** What is meant by "Upper and Under Classmen"
Answer: Upper Classmen are (for purposes of the contest) seniors and/or graduate students. Lower Classmen are Freshmen, Sophomores and Juniors
9. **Question:** Does the 1/3 under classmen rule apply to the people present at the fly-off site?
Answer: No. The 1/3 , 2/3 distribution applies to the team as a whole, from the entry date through the end of the contest. Not all team members must be present at the fly-off.
10. **Question:** Is it allowed to have/declare more than 1 pilot in a team (in case one of them can not go to the contest, or simply have a back-up pilot)?
Answer: Yes, teams may register multiple pilots as long as each meets the requirements listed in the rules.
11. **Question:** Can the team members be changed?
Answer: Team members may be updated/changed at any time during the contest provided the required team makeup is maintained. We will make a "One Time" update to the posted team member lists posted on the website. Teams wishing a team member list update must submit an updated copy of the contest entry form with all fields fully filled (but only the team member names may be changed) between 1 Feb 2009 and 15 Feb 2009.
12. **Question:** Can we have corporate sponsors? If so, can we put their logo on the UAV at any place that pleases them?
Answer: Teams may solicit and accept sponsorship in the form of funds or materials and components from commercial organizations. All design, analysis and fabrication of the contest entry is the sole responsibility of the team members. Sponsor and university decals or logos may be placed as desired. Teams should make sure that the final color scheme of the aircraft provides good visibility of the aircraft location and orientation for the pilot.
13. **Question:** How is the radio fail-safe described in the safety supplement to be implemented.
Answer: This is a feature available in many production RC radio systems. It is **required** that your radio system be able to provide this function.
14. **Question:** When you check the CG, what kind of a point will you use? For example will it be checked with fingers or dowels or something even sharper?
Answer: The CG check will be coincident with the structural verification test described in the Safety Requirements supplement to the basic rules. Specifically, two team members will be asked to pick the aircraft up by the wing tips using their hands (usually a clenched fist placed under the wing at the desired location works well). They will (gently) lift the aircraft at it's full contest weight by the wing tips at the marked axial CG location. For aircraft configurations where the CG is not within the chord of the wing tips, a third lift point, located as far from the CG as possible, will be used to balance aircraft.

[\[Top\]](#) [\[AIAA Student Design/Build/Fly Competition homepage\]](#)[\[AIAA Homepage\]](#)