

31oct12



2012/13 Rules and Vehicle Design

Initial Rules Posting: 18 Aug 2012

Latest Update: 31 oct 12

Entry Deadline: 31 Oct 2012

The contest rules may be augmented/supplemented at any time during the competition through the Q&A process.

Summary:

The AIAA through the Applied Aerodynamics, Aircraft Design, Design Engineering and Flight Test Technical Committees and the AIAA Foundation invites all university students to participate in the **Cessna Aircraft Company/Raytheon Missile Systems - Student Design/Build/Fly Competition**. The contest will provide a real-world aircraft design experience for engineering students by giving them the opportunity to validate their analytic studies.

Student teams will design, fabricate, and demonstrate the flight capabilities of an unmanned, electric powered, radio controlled aircraft that can best meet the specified mission profile. The goal is a balanced design possessing good demonstrated flight handling qualities and practical and affordable manufacturing requirements while providing a high vehicle performance.

To encourage innovation and maintain a fresh design challenge for each new year, the design requirements and performance objectives will be updated for each new contest year. The changes will provide new design requirements and opportunities, while allowing for application of technology developed by the teams from prior years.

Check the rules package carefully as items and approaches that were legal in past years may not be legal for this contest year. Only the contents of this Rules package, the 2013 FAQ, and 2013 Q&A documents hold bearing on the requirements and/or allowances for the current contest year. It is the responsibility of the teams to know and follow all provided rules, the FAQ, and all contest day briefings.

Cash prizes are \$2500 for 1st, \$1500 for 2nd and \$1000 for 3rd place. The winning team will be invited to present their design at an AIAA conference. The team with the best Report Score will receive a \$100 prize from the Design Engineering Technical Committee.

Judging:

Students must design, document, fabricate, and demonstrate the aircraft they determine to be capable of achieving the highest score on the specified mission profile (s). Flight scores will be based on the demonstrated mission performance obtained during the contest.

Each team must also submit a written Design Report. A maximum of 100 points will be awarded for the team design report. The overall team score is a combination of the Design Report score, Flight score and Rated Aircraft Cost (RAC). The team with the highest overall team score will be declared the winner. Scores will be FINAL 7 working days after the completion of the contest. This period will allow for review of the scores in a timely fashion following the contest.

All submitted reports are the property of AIAA, Cessna and Raytheon and may be published or reproduced at their discretion.

Contest Site:

Host for the competition will be Raytheon Missile Systems. The fly-off is planned to be held at the TIMPA field in Tucson, AZ. Details on the contest site and schedule will be sent to registered teams early in the fly-off calendar year. You can check on historical weather conditions at www.weatherbase.com or www.weatherunderground.com.

Teams are advised to check with their airlines on what materials they will be allowed to bring both to and from the contest site. Hazmat items like paints, thinners and glues may need to be purchased locally and PROPERLY disposed of following the contest.

Team Requirements:

All team members (except for a non-student pilot) must be full time students at an accredited University or College and student members of the AIAA. At least **1/3** of the team members must consist of Freshman, Sophomores or Juniors. The pilot must be an AMA (Academy of Model Aeronautics) member. Teams may use a non-university member for the pilot if desired. We will provide qualified pilots at the contest on an as-available basis to assist teams who are unable to have their pilot attend.

Team members may be updated/changed at any time during the contest but must always comply with the **1/3** rule. Following the initial team postings at the contest beginning we will make a "One Time" update to the team member lists posted on the website. Teams wishing a team member list update must submit an updated copy of the contest entry form with all fields fully filled (but only the team member information may be changed). We will notify teams when the website update change information may be sent, normally in February.

Each educational institution may submit one (1) team entry. The team members may be changed during the contest period, so schools may use an internal selection process to determine their final design and team members prior to the written report submission and fly-off. For schools with multiple campuses in different cities each campus will be considered as a separate entity.

- z Two or more schools may combine to submit a single entry.
- z Schools which already have an entry may not have additional students from their school participate as members of a team from a different (shadow) school.

The number of entries is limited to a maximum of 100 teams. If more than the maximum number of team entries is received during the submission period a random selection will be used by the judges to down-select to the final team list.

Past Year Reports:

Winning team design reports from prior contest years are posted on the contest website as examples. Note that the formatting and content has evolved from one year to the next. Only the rules noted in this document apply for the current year. The top scoring report(s) from this year's contest will be placed on the contest web site for the next year's competition.

Sponsorship:

Teams may solicit and accept sponsorship in the form of funds or materials and components from commercial organizations. All **design, analysis and fabrication** of the contest entry is the sole responsibility of the **student** team members.

Schedule:

A completed electronic entry must be **RECEIVED** by 5 PM US East Coast Time on **31 October 2012**. Entry forms may not be submitted before **15 October**.

- z The DBF entry form is different from the ones used for other AIAA student competitions. The DBF entry form can be found on the contest web site. It must be submitted by e-mail to the contest administrator at director@aiaadbf.org.
 - Be sure to include **ALL** information requested in the form. We will use the first (valid) entry received so be sure all supplied information is correct the first time..
 - **Incomplete entry forms will not be accepted. Incomplete forms will be returned for correction and may miss the deadline**
- z *It is the teams responsibility to make sure the e-mail contact addresses they supply remain active during the entire period from entry to the close of the competition, as e-mail will be the primary means to provide information and updates. Do not use an internal team correspondence e-mail list server as your point of contact e-mail address.*
- z *Note: The AIAA mail servers will not send e-mail to @hotmail.com addresses. Do NOT use a hotmail address for any of your team contacts or e-mail.*

Design reports must **ARRIVE** at the designbuildfly@gmail.com email by 5 pm US East coast time on **25 February 2013**.

- z Reports will be judged "as received", no corrections/additions/changes will be made by the organizers so check your reports carefully before sending them.
- z **Teams may only submit one report copy, any copies received after the initial submission will be deleted.**

Submission of reports electronically only (no hard copy required) is new this year. The details for the electronic report format and submission are at the end of the report section in this rules document.

The contest is scheduled for **19-21 April 2013**. The competition is anticipated to run from 8AM to 7PM on Friday, 7AM to 7PM on Saturday and 7AM to 6PM Sunday. Awards will be presented at 5:30PM on Sunday. All teams should plan their travel so that they may stay for the awards presentations on Sunday. A final contest schedule will be e-mailed to the teams prior to the contest date.

Tech inspections will begin on Friday and will continue as required on Saturday and Sunday.

To help streamline the contest flow and maximize opportunities for each team to get their flights in the Tech inspections will be conducted in the same order as the flight rotation (which is based on report scores) so that the first teams inspected will be the first teams in the flight queue. Teams may use the sequence to help estimate when they need to arrive at the contest site to make sure they do not miss their slot in the first tech inspection rotation.

Note: All schedule deadlines are strictly enforced.

Late entries will NOT be accepted. Late report submissions will NOT be judged. Teams who do not submit the required electronic report will NOT be allowed to fly. It is the team's responsibility to assure that all deadlines are known, understood and met.

Communications:

The contest administration will maintain a World Wide Web site containing the latest information regarding the contest schedules, rules, and participating teams. The contest web site is located at:

<http://www.aiaadbf.org>

Questions regarding the contest, schedules, or rules interpretation may be sent to the contest administrator by e-mail at:

director@aiaadbf.org

Questions received prior to the official entry submission date will not be answered directly. Select questions "may" be answered in the FAQ prior to the entry submission date. Official questions and answers received following the entry submission date will be posted on the website.

This year, the DBF Organizing Committee will utilize Facebook as an additional means of communicating with the teams during the contest weekend only. This will NOT be a means of communicating rules, FAQ's, protests, etc, but only used in case of emergencies, weather delays or contest weekend schedule updates. Additional information will be included in a contest site/ schedule email to be sent out to the registered teams prior to the fly-off..

Aircraft Requirements - General

- ⌚ The aircraft may be of any configuration except rotary wing or lighter-than-air.
- ⌚ No structure/components may be dropped from the aircraft during flight.
- ⌚ No form of externally assisted take-off is allowed. All energy for take-off must come from the on-board propulsion battery pack(s).
- ⌚ Must be propeller driven and electric powered with an unmodified over-the-counter model electric motor. May use multiple motors and/or propellers. May be direct drive or with gear or belt reduction.
- ⌚ Motors may be any commercial brush or brushless electric motor.
- ⌚ For safety, each aircraft will use a commercially produced propeller/blades. Must use a commercially available propeller hub/pitch mechanism. Teams may modify the propeller diameter by clipping the tip and may paint the blades to balance the propeller. No other modifications to the propeller are allowed. Commercial ducted fan units are allowed.
- ⌚ You can change the propeller diameter/pitch for each flight attempt.
- ⌚ Motors and batteries will be limited in current draw by means of a **20** Amp fuse in the line from the positive battery terminal to the motor controller.
 - Fuse(s) must be located such that no propulsion system component: motor; motor controller; or battery may see more current than the stated limit (fuse value).
 - Only ATO or blade style plastic fuses may be used.
- ⌚ Must use over the counter NiCad or NiMH batteries. For safety, battery packs must have shrink-wrap or other protection over all electrical contact points. The individual cells must be commercially available and the manufacturers label must be readable/documented (i.e. clear shrink wrap preferred). All battery disconnects must be "fully insulated" style connectors.
- ⌚ **Maximum propulsion battery pack weight is defined in the mission rules section.** This battery pack must power propulsion systems only. Radio Rx and servos **MUST** be on a separate battery pack. Batteries may not be changed or charged between sorties during a flight period.
- ⌚ Aircraft and pilot must be AMA legal. This means that the aircraft TOGW (take-off gross weight with payload) must be less than 55-lb, and the pilot must be a member of the AMA.
- ⌚ Since this is an AMA sanctioned event, the team must submit proof that the aircraft has been flown prior to the contest date (in flight photo) to the technical inspection team. We will provide qualified pilots at the contest on an as-available basis to assist teams who are unable to have their pilot attend.
- ⌚ **The aircraft must remain substantially the same as documented in the report (for example you can not change a flying wing design to a conventional tail design). You may make small modifications to the design to improve flight performance after the report submission (one example would be changing a control surface size).**

Aircraft Requirements - Safety

All vehicles will undergo a safety inspection by a designated contest safety inspector prior to being allowed to make any competition flight. **All decisions of the safety inspector are final.**

To speed the tech inspection process each team must present a signed *Pre-Tech and First-Flight Certification* when called to begin their on-site tech inspection. Teams may not begin the on-site tech inspection without a completed certification. The *Pre-Tech and First-Flight Certification* sheet is available on the contest website.

The Pre-Tech must be conducted by, and signed off by, a non team member RC pilot or the team faculty advisor. The Pre-Tech will cover the same safety of flight requirements as the on-site tech inspection and will assist teams in making sure they are ready and able to pass the on-site tech inspection the first time. An expanded First-Flight requirement, which also must be signed off by a non team member RC pilot or the team faculty advisor, requires demonstration of a complete flight including take-off, flying a minimum flight pattern, and landing in a pre-designated location without damage to the aircraft. The non team member RC pilot who signs the inspection and flight certifications may be the same as a team's non-student contest pilot.

Safety inspections will include the following as a minimum:

- Physical inspection of vehicle to insure structural integrity.
 1. Verify all components adequately secured to vehicle. Verify all fasteners tight and have either safety wire, locktite (fluid) or nylock nuts. Clevises on flight controls must have an appropriate safety device to prevent their disengaging in flight.
 2. Verify propeller structural and attachment integrity.
 3. Visual inspection of all electronic wiring to assure adequate wire gauges and connectors in use.
 4. Radio range check, motor off and motor on.
 5. Verify all controls move in the proper sense.
 6. Check general integrity of the payload system.
- Structural verification.
 - All aircraft will be lifted with one lift point at each wing tip to verify adequate wing strength (this is "roughly" equivalent to a 2.5g load case) and to check for vehicle cg location. Teams must mark the expected empty and loaded cg locations on the exterior of the aircraft. Special provisions will be made at the time of the contest for aircraft whose cg does not fall within the wing tip chord. This test will be made with the aircraft filled to its maximum payload capacity.
- Radio fail-safe check. All aircraft radios must have a fail-safe mode that is automatically selected during loss of transmit signal. The fail-safe will be demonstrated on the ground by switching off the transmit radio. During fail safe the aircraft receiver must select:
 - Throttle closed
 - Full up elevator
 - Full right rudder
 - Full right aileron
 - Full Flaps down (if so equipped)

The radio Fail Safe provisions will be strictly enforced.

- All aircraft must have a mechanical motor arming system separate from the onboard radio Rx switch. This **MUST** be the contest specified "blade" style fuse. This device must be located so it is accessible by a crewmember standing **ahead** of the propeller(s) for pusher aircraft, and standing **behind** the propeller(s) for tractor aircraft (i.e. the crew member must not reach across the propeller plane to access the fuse). The "Safety Arming Device" will be in "Safe" mode for all payload changes. The aircraft Rx should always be powered on and the throttle verified to be "closed" before activating the motor arming switch. Fuses **MUST be mounted on the outside the aircraft** (they can not be behind an access panel or door) and **MUST** act as the "safing" device.

Note: The aircraft must be "safed" (arming fuse removed) any time the aircraft is being manually moved, or while loading/unloading payload during the mission. The arming fuse must be removed anytime the aircraft is in the hanger area.

Scoring:

In the event that, due to time or facility limitations, it is not possible to allow all teams to have the maximum number of flight attempts, the contest committee reserves the right to ration and/or schedule flights. The exact determination of how to ration flights will be made on the contest day based on the number of entries, weather, and field conditions. In the event of a tie, Report Score will take precedence over Flight Score as a tie-breaker.

Each team's overall score will be computed from their **Written Report Score**, **Total Flight Score** and **Rated Aircraft Cost** using the formula:

$$\text{SCORE} = \text{Written Report Score} * \text{Total Flight Score} / \text{RAC}$$

The total flight score is the sum of the individual mission flight scores: **Total Flight Score = M1 + M2 + M3**

The RAC is a function of empty weight and size factor. **RAC = Sqrt(EW * SF) / 10**

- Empty weight will be measured after each successful scoring flight: **EW = Max(EW1, EW2, EW3)**
 - EW_n** is the post flight weight with the payload removed
- Size factor, **SF = X_{max} + 2* Y_{max}**
 - SF measurements will be made with the aircraft in it's full flight configuration.
 - X_{max}** is the longest possible dimension in the direction of flight.
 - Y_{max}** is the longest possible dimension perpendicular to the direction of flight.
 - Measurements will be made "point-to-point" on the aircraft so may not necessarily be parallel to the ground or the the aircraft flight axis.
 - Point-to-Point measurements will curve around portions of the aircraft as needed.
 - The measurement path with the shortest length, going either "over" or "under" the aircraft, will be used.
 - If the wing tip trailing edge or the horizontal tail trailing edge is aft of the fuselage aft point then **teams** must bring a board with them that spans the wing/horizontal tip trailing edges to create a measurement reference.

Mission Task Matrix:

Joint Strike Fighter

General:

- Battery pack(s) maximum weight limit is **1.5** lb.
- Teams will be allowed a maximum of **4** flight attempts or **3** successful scoring flights. Once a mission has a successful scoring flight it may NOT be repeated to try to improve the score.
- All payloads must be secured sufficiently to assure safe flight without possible variation of aircraft cg during flight.
- Assembly/flight line crew is limited to pilot, observer and 1 ground crew.
- Scoring measurement units are feet; lbs.; and seconds.

Mission Sequence:

- Missions must be flown in order. A new mission can not be flown until the team has obtained a successful score for the preceding mission.**
- Aircraft must be designed to be capable of performing all required missions.**
 - Specifically this requires that teams must show that all payloads fit in the aircraft during the tech inspection.**
 - Teams will be asked to load configuration #1 (of mission #3) and must present photographs showing configurations #2-6 installed.**
 - Aircraft must pass the wing tip load test with the larger of 4 internal stores or the maximum number of internal stores the team will attempt to fly for mission #2 plus one store "Der Red Max" on each inboard wing pylon**
 - The number of internal stores demonstrated will be recorded and can not be altered after completing tech inspection.**
- The aircraft will enter the assembly area with the payload for mission 2 and 3 uninstalled.
- The team will have a total of 5 minutes to load the payload and checkout the aircraft systems as fully functional.
- There is no work allowed on the aircraft after the loading/checkout time.
 - The RC receiver should be able to be turned on externally or must be left on. You will not be allowed to re-open any compartment after the loading/checkout time to turn on the receiver.**
- Only the assembly crew member, pilot and pilot assistant may go to and enter the staging box.
 - After the checkout is complete the assembly crew member may be swapped for a different flight line crew member if desired.
- The initial upwind turn on the first lap of each mission will occur after passing the turn judge (signaled by raising a flag). The aircraft must remain in unaided visual control distance of the pilot at all times. The **Flight Line Judge** may require turns to be made to remain in a safe visual control range at his discretion.

Missions:

- Aircraft will use ground rolling take-off and landing
 - Missions will simulate take-off from a small austere field.
 - The aircraft will be placed such that all ground contact points are completely inside an approximately 30 x 30 ft square marked on the runway.

- Aircraft must successfully take-off before crossing any edge of the square.
- ⌚ Aircraft must complete a successful landing at the end of each mission for the mission to receive a score.
 - A successful landing is outlined in the general mission specification section below.

⌚ **Mission 1 - Short Take-off**

- Take-off within the prescribed area.
- Maximum number of complete laps within a **4** minute flight time
- Time starts when the throttle is advanced for the (first) take-off (or attempt)
- A lap is complete when the aircraft passes over the start/finish line in the air
- Mission performance will be normalized over all teams successfully completing this mission.
- Mission score $M1 = 2 * (N_Laps_Flown / Max_N_Laps_Flown)$
- Must complete a successful landing to get a score

⌚ **Mission 2 - Stealth Mission**

- Take-off within the prescribed area.
- 3 Lap internal-stores flight.
- Stores must be carried internal to the aircraft in the main fuselage (not a secondary pod) or completely inside the wing.
 - Access to the stores for loading must be through the lower surface of the aircraft, representative of bay doors though the doors need not be mechanized.
 - Stores must be aligned to the direction of flight (tails aft, body along flight axis).
 - Internal stores must be secured to a mounting structure/rack that is a permanent part of the aircraft structure.
 - They must be secured and positioned such that they "could" be released "down" one at a time.
 - Stores must not contact each other or any part of the aircraft structure except for the specified mount/rack.
 - Store mounting points must secure the store by/on the store body.
 - Stores do not need to be capable of remote release (stores will not be released as part of the flight).
 - No special fairings or blisters may be added to the aircraft, all external surfaces must be the same for all 3 missions.
 - Weight of internal fixtures used to secure stores WILL be included in the Empty_Weight measurement.
- Mission performance will be normalized over all teams successfully completing this mission.
- Mission score $M2 = 4 * (N_Store_Flown / Max_N_Store_Flown)$
- Must complete a successful landing to get a score

Stores Configuration:

Internal	Mini-Max	Number determined by team - May not be zero and may not exceed number demonstrated in tech inspection
----------	----------	--

⌚ **Mission 3 - Strike Mission**

- Take-off within the prescribed area.
- 3 lap mixed-stores flight.
- Payload will be a random draw of internal and external stores (Roll of 1 dice).
 - Teams will roll the dice when entering the assembly area.
- Internal stores must follow requirements outlined for Mission 2
- External stores must be wing pylon mounted and fully external to the wing profile (no submerged stores).
 - Store fins must be below the wing lower surface trailing edge height.
 - Store mounting points must secure the store by/on the store body
 - Weight of removable pylons WILL NOT be included in the Empty_Weight (EW3) measurement
 - External stores may not overlap/block the access/deployment area of internal store location(s).
 - Stores must have a minimum store-to-store separation of 3" on centerline.
 - The most inboard store(s) centerline must be at least 3" from the aircraft centerline.
- Mission performance will be normalized over all teams successfully completing this mission.
- Mission score $M3 = 6 * (Fastest_Time_Flown / Team_Time_Flown)$
 - Time starts when the throttle is advanced for the (first) take-off (or attempt)
 - Time ends when the aircraft passes over the finish line (in the air) at the completion of the last lap.
- Must complete a successful landing to get a score

Stores Configurations: **(corrected load-out)**

Payload Configuration (roll dice)		1	2	3	4	5	6
Internal	Mini-Max	4	-	2	-	-	1
Left Wing	Mini Honest john	-	-	-	2	-	-
	High Flyer	-	1	-	-	1	1
	Der Red Max	1	1	1	-	1	1
Right Wing	Mini Honest john	-	-	2	2	2	1
	High Flyer	-	1	-	-	-	1
	Der Red Max	1	1	-	-	-	-

Stores:

- ⌚ Each team will provide a case containing the stores inventory defined below, including the required removable pylon assemblies.
- ⌚ Stores case must have a latching lid and be able to be opened on one side only (no collapsing cases)
- ⌚ Store mounts (pylons) are not part of store weight.
 - External pylons will be removed for empty weight (EW) measurements.
 - Internal store mounting provisions will be included in EW measurement.
 - Store minimum weights will be verified after each successful flight (not during the tech inspection)
- ⌚ Store may have no additional "features" beyond what is defined in the kit (ie. they must be built exactly to the kit instructions and configuration with the sole exception of adding internal ballast)..
- ⌚ Required stores inventory: **(corrected weights)**
 - min 4 x Estes p/n 002445 Mini-Max - internal payload - ballast to 0.25 lbs each (minimum)
 - 2 x Estes p/n 002178 Hi-Flyer - external payload - ballast to 0.50 lbs each (minimum)
 - 4 x Estes p/n 002446 Mini Honest John - external payload - ballast to 0.75 lbs each (minimum)
 - 2 x Estes p/n 000651 Der Red Max - external payload - ballast to 1.0 lbs each (minimum)
- ⌚ Each store must have it's model (name) and the required minimum weight printed on the body exterior.
- ⌚ For foreign teams, the Estes overseas distributor is:

Logic RC Limited
 12-18 Hartham Lane
 Hertford, SG14 1QN, United Kingdom
 Tel: +44(0) 01992 558226
 Email: mail@logicrc.com
 Website: www.logicrc.com

Flight Line Order:

- ⌚ A **flight order** list will be generated and **emailed to the teams on the Wednesday prior to the fly-off weekend**. Teams will always rotate in this order. The flight order will be repeated continuously.
 - The flight order list will carry over from Friday to Saturday and Saturday to Sunday at what ever spot in the rotation it leaves off.
 - Each team's position in the flight order will be determined from their written report score, highest report score goes first.
 - Report scores will be available following the pilot briefing at the start of the contest (they will not be included with the rotation sequence e-mail).
- ⌚ There will be four **staging box** positions near the flight line.
- ⌚ If you are not ready to enter a **staging box** when your rotation number comes up you will miss your opportunity for that rotation.
Note: Teams will be notified when to enter the staging box. It is each team's responsibility to monitor the notifications from the scoring table in order to respond if ready. A contest official will be available to help teams enter the **staging box**.
- ⌚ Electing to enter one of the **staging box** positions on your turn in the rotation order **will constitute using a flight attempt**.
 If you choose to leave the **staging box** for any reason you will **forfeit that flight attempt**.
 If you go to the flight line and are not able to begin your flight when instructed you will **forfeit that flight attempt**.

General Mission Specification and Notes:

- ⌚ The aircraft propulsion system(s) must be "safed" (fuse removed) during any time when crew members are preparing/handling the aircraft.
- ⌚ Maximum flight support crew is: **pilot, observer, and ground crew**.
- ⌚ Observer and all ground crew must be students. **Only the pilot may be a non-student**.
- ⌚ The upwind turn will be made after passing the upwind marker. The downwind turn will be made after passing the downwind marker. Upwind and downwind markers will be 500 ft from the starting line. Aircraft must be "straight and level" when passing the turn marker before initiating a turn.
- ⌚ Aircraft must land on the paved portion of the runway. Aircraft may "run-off" the runway during roll-out. Aircraft may not "bounce" off the runway.
- ⌚ **Aircraft obtaining "significant" damage during landing will not receive a score for that flight. Determination of "significant" is solely at the discretion of the Flight Line Judge.**
- ⌚ Flight altitude must be sufficient for safe terrain clearance and low enough to maintain good visual contact with the aircraft. Decisions on safe flight altitude will be at the discretion of the Flight Line Judge and all rulings will be final.

Additional information is included in the [FAQ](#) (Frequently Asked Questions).

Flight Course:

The orientation (direction) of the flight course will be adjusted based on the prevailing winds as determined by the Flight Line Judge. The flight course will be positioned to maintain the greatest possible safety to personnel and facilities. The nominal flight course is shown in the Figure below.

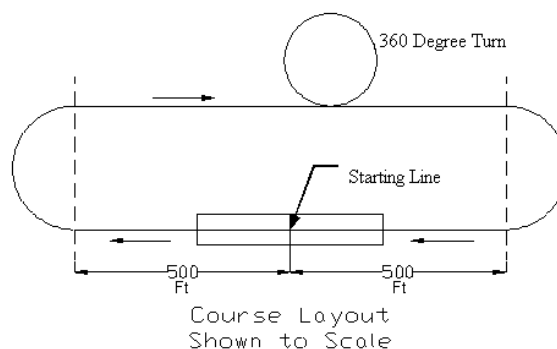

Protest Procedure:

Submitting a protest is a serious matter and will be treated as such. Teams may submit a protest to the Contest Administration at any time during the competition. Protests may not be submitted after the conclusion of the competition. Protests must be submitted in writing and signed by the team advisor, designees are not allowed for protest submissions. If the team advisor is not present, he may FAX or email a signed protest to the team for them to present. Remotely submitted protests must be on hard copy (printed by the team) and have the advisors signature. A phone number where the advisor may be contacted must be provided.. Protests may be posted for review at the decision of the administration.

Protests and penalties (up to disqualification from the contest for deliberate attempts to misinform officials, violate the contest rules, or safety infractions) will be decided by the Contest Administration. **Protests submitted but not upheld by the judges may be given a penalty of the loss of one flight score to the team submitting the protest.** The decision of the Contest Administration is final.

Design Report:

Each team will submit a judged design report as outlined below and in the **SCHEDULE** section above.

Note: Reports must strictly adhere to the following requirements. Failure to meet requirements will result in penalties that range from score reduction to elimination from the contest.

- ⌚ Reports must have the University name on the cover page.
Reports missing this identification information will not be scored.
- ⌚ Absolute maximum page count for the report is **60 pages**, the PDF reader "pages" value will be used as the official page count.
Reports exceeding the maximum page count will be given a 10 point penalty for each additional page.
- ⌚ Report PDF must be formatted as 8.5 x 11" pages.
 - May use 11x17" pages for the drawing package.

- ⌚ Reports will be scored on a 100 point basis following the guidelines outlined below.
All information used for scoring **must be in the outlined sections, content that is out of sequence, including the drawing package, will be treated as missing** and scored accordingly.
- ⌚ All reports must be one and one half line spacing, 10-pt Arial font. Tables and figures should be clear and readable for the judges. The reports will be judged on format and readability.
- ⌚ **ALL** items requested below should be present, easy to locate and identify, well documented and in the correct section for full scoring.
- ⌚ Examples of winning team design reports from prior contest years are posted on the contest website. Note that the formatting and content has changed from one year to the next. Prior year reports may not reflect or meet the rules listed for the current year.

Design Report

All section scores will include format, completeness and readability

1. Executive Summary: (10 points):
 - ... Provide a summary description of your selected design and why it is the best solution to the specified mission requirements.
 - ... Describe your key mission requirements and design features keyed to those requirements.
 - ... Document the performance/capabilities of your system solution.
2. Management Summary (5 points):
 - ... Describe the organization of the design team.
 - ... Provide a chart of design personnel and assignment areas.
 - ... Provide a milestone chart showing planned and actual timing of the design / fabrication / testing processes.
3. Conceptual Design (15 points):
 - ... Describe mission requirements (problem statement).
 - ... Translate mission requirements into design requirements.
 - ... Review solution concepts/configurations considered.
 - ... Describe selection process and results.
4. Preliminary Design (20 points):
 - ... Describe design/analysis methodology
 - ... Document design/sizing trades
 - ... Describe/document mission model (capabilities and uncertainties)
 - ... Provide estimates of the aircraft lift, drag and stability characteristics.
 - ... Provide estimates of the aircraft mission performance.
5. Detail Design (30 points total. 15 points for discussion items, 15 points for drawing package):
 - ... Document dimensional parameters of final design.
 - ... Document structural characteristics/capabilities of final design.
 - ... Document systems and sub-systems design/component selection/integration/architecture.
 - ... Document Weight and Balance for final design. Must include a Weight & Balance table for the empty aircraft and with each of the possible payloads
 - ... Document **flight** performance parameters for final design.
 - ... Document **mission** performance for final design.
 Drawing Package
 - ... 3-View drawing with dimensions.
 - ... Structural arrangement drawing.
 - ... Systems layout/location drawing.
 - ... Payload(s) accommodation drawing(s).
6. Manufacturing Plan and processes (5 points):
 - ... Document the process selected for manufacture of major components and assemblies of the final design.
 - ... Detail the manufacturing processes investigated and the selection process/results.
 - ... Include a manufacturing milestone chart showing scheduled and actual event timings.
7. Testing Plan (5 points):
 - ... Detail testing objectives, schedules, and check-lists.
8. Performance Results (10 points):
 - ... Describe the **demonstrated** performance of key subsystems and compare it to predictions from Section 5. Explain any differences and improvements made.
 - ... Describe the **demonstrated** performance of your complete aircraft solution and compare it to predictions from Section 5. Explain any differences and improvements made.

Design Report Electronic Submission

Each team must provide an electronic copy of their final design report for the report judging as outlined below.

- ⌚ Electronic copy must **Arrive** at the designbuildfly@gmail.com email by 5PM US East Coast time on 25 February 2013.

- ⌚ Electronic report files must be named: "2013DBF_*university*.PDF"
- ⌚ Electronic report must be a single file with all figures/drawings included in the proper report sequence in PDF format. (Free PDF file conversion programs are available on the Internet, such as www.pdf995.com.)
- ⌚ Electronic reports should have all figures compressed to print resolution to minimize file size.
- ⌚ Electronic reports must be less than **20 MB** in size (including encoding for e-mail transmission).

Reports not following the name format or exceeding the file size will be rejected. We will notify the team "if" the reports do show up in the email 'in' box. If reports are rejected by the email system for being too large we will NOT be able to send a notification of the problem to the team!

[\[AIAA Student Design/Build/Fly Competition homepage\]](#) [\[AIAA Homepage\]](#)



Please remember that questions submitted prior to the entry deadline of 31 October that were not answered in the FAQ must be resubmitted.

The Q&A will be updated once a week if new questions arrive during that week. Be sure to **Read the Rules, FAQ and Q&A** before submitting questions to avoid duplication. Questions specifically addressed in the rules or FAQ may be skipped for Q&A responses at the judges discretion.

DBF Q&A

21 Feb 2013

Common Topics:

- ε **Rules** – If you haven’t read the rules lately you should re-read them.
- ε **72 mHz Frequencies** - If any teams are still planning to use an old-style 72 mHz radio system please send an email **in January** listing your intent and requesting a channel assignment. We will try to honor channel requests on a first-come basis.
- ε Invalid contact email addresses - The following supplied contact email address's have been returned as invalid and have been deleted. If these were for your team you will need to send corrected addresses to continue to receive contest information

General Questions

Questions:	Answers:
For the AIAA: DBF Design Report should the units used for the calculations be expressed in Imperial or S.I.?	Since the rules are written for Ft/Lb/Sec you should include both units if using SI units for your internal team design calculations..
The rules include "Batteries may not be changed or charged between sorties during a flight period." To which period refer 'sorties' here?	None of the missions in this years contest have multiple sorties/flight in a single mission attempt/period so that clause won't be a factor. You may charge batteries between each mission attempt, which are sequenced by the rotation queue described in the rules.
Since teams have asked for a confirmation, the rules are correct as written that there is no hard-copy report required this year, just the electronic copy as outlined in detail.	
	The rules say: The aircraft must remain substantially the same as documented in the report (for example you can not change a flying wing design to a conventional tail design). You may

We have received many questions on what is allowed to be changed following report submission.

make small modifications to the design to improve flight performance after the report submission (one example would be changing a control surface size).

Changes should not change the design (or scoring features) from the results of the design selection process you documented in your report. Final decisions on admissibility of changes will be made by the tech inspectors and judges at the contest as they will be the ones with access to both the report configuration drawing and the actual aircraft.

Mission Questions

Note: There has been a change in the store inventory. It was brought up that the Quark was too small to be able to ballast to the required weight. The internal store has been changed. See the draft rules for the new specification.

Questions:	Answers:
<p>We have discovered that there are two different Mini-Max generations. The early kits (balsa nose cone) have a length (as listed on the package) of 9.75". The later/current kits (plastic nose cone) have a length (as listed on the package) of 8.8" Photos of each package are in the column to the right.</p> <p>Both kits will be accepted as legal for the DBF, and both kits may be assembled (by adjusting the length of the body tube) to the current 8.8" total length.</p> <p>Most websites listing the Mini-Max, including the Estes site, list the original 9.75" length. Only the Tower Hobbies site has been found to list the current 8.8" length. http://www3.towerhobbies.com/cgi-bin/WTI0001P?I=LXWGN2&P=8</p>	
<p>Our set of Mini-Max's, although ordered from the same online retailer, came in two different nose materials. Some kits had noses made out of balsa wood, and some made out of white plastic.</p>	<p>As long as the rockets meet the diameter and length listed by the manufacturer, and are ballasted to the correct contest weight, they are acceptable. Either material for the nose is allowed.</p>
<p>While preparing the fins on the stores during assembly, the instructions direct us to sand the edges of each fin. How much material can be sanded away from the fins before the rocket is no acceptable for use?</p>	<p>As noted in the rules, the rockets should be prepared according to the supplied instructions. We will have officially assembled rockets at the contest for comparison. Obvious attempts to modify the rockets to improve a teams contest score potential will require those rockets be replaced or modified back to manufacturer specifications.</p> <p>Also in the rules, each store must have it's model (name) and the required minimum</p>

How accurate do the fins need to be for the internal and external stores with respect to spacing between the fins?	weight printed on the body exterior. Decals and paint colors are up to the team provided the required marking is clearly visible to inspectors.
Can we add any structural support to the fins of the rockets such as small fillets?	Yes provided they comply with the notes above.
May the external payloads have slight modifications made to them in the form of embedding a small pin into the body of the payload which will be used as an interlocking mechanism with a notched rod within the aircraft wing? Can removable external pylons be permanently mounted to the rockets and included in the rocket weight?	This is in the rules: Store may have no additional "features" beyond what is defined in the kit (ie. they must be built exactly to the kit instructions and configuration with the sole exception of adding internal ballast). The rockets do not <u>need</u> to contain the following specific components: parachute, motor or the stock rocket launch rail interface tube/straw (they are optional).
If we plan on flying less than (4) internal stores, do we still need to load (4) to pass tech inspection?	This is in the rules: Aircraft must pass the wing tip load test with the larger of 4 internal stores or the maximum number of internal stores the team will attempt to fly for mission #2 plus one store "Der Red Max" on each inboard wing pylon
Are there any limits to what material may be used to ballast the stores, such as batteries?	Store ballast must be inert. You may not use batteries, active or un-connected. You should not use toxic or hazardous materials, including lead.
What are the error margins for the weight of the stores?	Stores must meet or exceed the specified weight using the official contest (commercial) scale.
It is specified in the rules that all contact points must be in front of the line. However, it is not specified as to where they may be located. Does the airplane have to be placed in the center of the runway for the start of takeoff? Does the centerline of the aircraft have to be parallel to the centerline of the runway at the start of takeoff? Finally, does the aircraft have to attempt to takeoff parallel to the centerline of the runway.	The aircraft "must be placed such that all ground contact points are completely inside an approximately 30 x 30 ft square marked on the runway". The orientation of the aircraft must insure that the take-off flight path is safe. In general this requires the aircraft not cross or head toward the edge of the take-off area facing the spectator area.
Are we allowed to hold the aircraft stationary after throttle is advanced to build up initial thrust?	No.
For mission one is it mandatory to fly the full 4 min. period or can one land before that period (due to depleted batteries) to get a score?	You can stop short of the full time if needed to complete a on-runway landing and receive a score for the flight.
Can the airplane be hand launched?	No. That was only allowed/required in a prior years rules.
Would teams be allowed to bring their own inclined ramp to assist in takeoff?	No. You may not use any external take-off assistance.
Does the case have to be divided into sections or drawers for each type of rockets/pylon and must this case be included in the drawing in	There are no requirements for the case beyond what is listed in the rules. It does not need to be documented in the report.

the report?	
While we are loading stores from lower surface, can we turn the aircraft on it's side or upside down?	Yes. The stores must be able to be loaded/dropped in the direction that would be vertical when the aircraft is on the ground but you do not have to lie under the aircraft while loading it.
Can stores be secured with something protruding into the rear open end of the rocket?	No.
This year's competition mentions the aircraft will take-off from a "small austere field". Could this be elaborated on? Will the aircraft be taking off from a paved runway?	It is paved. The size of the takeoff area is constrained to represent a small field.

Aircraft Questions

General

Questions:	Answers:
<p>There have been some inquiries on how the SF will be measured. Using the aircraft in the answers box for a reference:</p> <p>X_max will be measured using a continuous tape measuring device and go from the tip of the nose, along the body surface which gives the shortest measurement (which would probably be along the sides for this example) to the "team supplied" board spanning the tips of the horizontal tail at the height which the tips contact the board. The rules do not specify the tip of the vertical tail for the measurement. (The tip of the vertical is excluded so the measurement will not be influenced by the height of the vertical, the base of the vertical is not exempted.)</p> <p>Y_max will be measured using a continuous tape measuring device from the left wing tip to the right wing tip including the distance required to go over or under the fuselage whichever is shorter including any effects of</p>	

<p>dihedral (which would probably be under the fuselage for this example).</p> <p>For a bi-plane or other multi-wing configuration measurements will be from the tip of which ever wing extends furthest from the centerline on each side. If the largest span is on a single wing the measurement will be tip-to-tip on that wing. If the largest span encompasses wings which have different axial locations the board technique will be used to create a pseudo-tip location of one wing at the axial location of the other wing for the measurement.</p> <p>For unconventional configurations teams should submit a detailed drawing of their configuration to obtain a definition of the measurements in advance of the fly-off. Drawings must have sufficient detail to identify the 3D geometry of your specific design (not a generic sketch), including the location of the propulsion system elements (to help identify the true flight direction)..</p>	
<p>I was wondering if we could use a microcontroller, such as an Arduino, to help stabilize our aircraft? Microcontrollers were discouraged for current limiting in last years Q&A section because of concern that the microcontroller would interfere with the fail-safe system. However, if microcontrollers comply with the fail-safe rules will they be allowed?</p>	<p>This is in the FAQ: Gyros are legal for stability purposes.</p> <p>We allow only model airplane rate gyros that are in line between the receiver and servo without heading lock mode. No microcontrollers, autopilots or any other form of stability augmentation is allowed.</p>
<p>If our aircraft contains high-lift devices such as flaps, do we need a certain clearance between the deployed flaps and the rockets?</p>	<p>There is no specified clearance. The tech inspectors must be able to easily see that they do not touch. The wing trailing edge/rocket fin height requirement will be enforced with flaps or ailerons in trail (neither depressed or reflexed).</p>
<p>Regarding the above explanation about SF</p>	<p>The example shown applies only to the specific geometry of the sample shown.</p>

<p>measurement. If I understand right only the fuselage with horizontal tail and wing is subjected to measurement. So if the undercarriage extends over the wing span, propeller disc extends over the wing span and vertical tail extends over the horizontal tail, this does not affect the SF measurement.</p> <p>Does Y_max include the external pylons and rockets?</p> <p>Do external stores count towards the size factor?</p>	<p>The rules for: "X_max is the longest possible dimension in the direction of flight." "Y_max is the longest possible dimension perpendicular to the direction of flight." apply to <u>all components</u> of the <u>aircraft</u>, except the vertical tail specifically excluded in the response above, including but not limited to wing, fuselage, horizontal tail, pods, pylons, landing gear etc. This includes propellers as if rotating, so is measured with the blade at it's furthest extent.</p> <p>Stores are not part of the "aircraft".</p>
<p>If we have a folding wing geometry, is the spanwise length of the plane measured to be the wing when it is folded up or the wing when it is fully extended? Would it matter if the wing could only extend via remote control, but not fold back up via remote control?</p>	<p>Per the FAQ "Variable geometry is allowed provided it is controlled remotely through the RC control system".</p> <p>As variable geometry configurations can change during the flight (and might be different than the configuration presented during the tech inspection), the SF will be measured with the aircraft in the configuration which yields the largest X_max and Y_max values..</p>
<p>The rules state there is a 1.5 lb battery weight limit. Is that the limit for all batteries being used in the plane at one time, or just the propulsion battery packs (i.e. are the receiver/servo/speed controller batteries included in this restriction)?</p>	<p>As noted in the rules in "Aircraft Requirements - General" the weight limit applies to the <u>propulsion</u> battery(s).</p>
<p>Are rubber bands legal to attach the wing to the fuselage?</p>	<p>Yes, typical model aircraft construction methods are allowed.</p>

Mission 2 Payload

Questions:	Answers:
<p>Do the payload rockets have to be off the shelf or can they be manufactured by the team, and if so, where can we find an official detailed drawing of them?</p>	<p>As detailed in the rules the rockets must be assembled by the team from the listed Estes rocket kits.</p>
<p>It is not clear to understand whether we have to put rocket fins on rockets in mission 2.</p>	<p>This is in the rules: Store may have no additional "features" beyond what is defined in the kit (ie. they must be built exactly to the kit instructions and configuration with the sole exception of adding internal ballast).</p> <p>Clearly the fins "are" a required part of the rocket.</p>
<p>Does any given internal store need to be "released"</p>	<p>The internal stores may be loaded such that they can be</p>

independently of the other internal stores, or can they be "released" by the order in which they are stored? In other words, is vertically stacking the internal rockets acceptable, provided they don't touch each other?	released in sequence. They do not need to be loaded such that they could be released simultaneously. If loading/releasing in sequence requires axial, lateral or rotational travel/movement of the store mount then the mount must be capable of providing that travel when the store is attached.
Do the restraints for the internal stores literally have to be able to release the rockets, or can the stores be supported from the underside, i.e. using Velcro straps? Is a rubber band in two places a sufficient measure to secure the rockets to their supporting structures?	This is in the rules: Stores do not need to be capable of remote release (stores will not be released as part of the flight). You may use restraints such as rubber-bands, zip-ties, metal straps or other securing devices to hold the stores to their mount. You may not rely only on magnets.
The rules state that, "Store mounting points must secure the store by/on the store body." Does this include the store nose cone as part of the body?	The nose cone is part of the body.
Can the stores be ballasted so that their center of gravity is at a location of our choosing? One of our ballasting techniques would require the need to cut off part of the bottom of the nose cone that is inserted into the rocket body. The external design of the rocket would not be modified at all. Would this be acceptable?	Stores may be ballasted at any cg but we recommend they be approximately in the center of the store. You may include ballast inside the nose-cone.
Are their requirements for the store hatch door(s)?	The hatch for internal store access need not be hinged. It may be secured using typical model aircraft hatch retention techniques. If a hatch departs the aircraft during flight the mission will be scored as incomplete.
For the bay door, are we allowed to have one continuous door spanning from the left around to the right side of the fuselage or does it have to be two doors that open in the middle?	It can be either provided the design is such that it "could" theoretically open in flight (it will not open in flight for the contest).
Beyond not touching, is there a minimum clearance required between the internal payload and non-mounting surfaces of the plane? Similarly, is there a minimum clearance required between internal payload fins/body components?	There is no specified clearance. The tech inspectors must be able to easily see that they do not touch.
When rockets are being loaded, is it required that they are kept in one piece, or can they be taken apart and then re-assembled once loaded?	Since the rockets must be loaded/stored such that they "could" be deployed (automated release is NOT required) they must be able to be installed/removed as assembled store units.

Mission 3 Payload

Questions:	Answers:
For a swept wing: Is "3 inches on or from the aircraft centerline" defined as the distance from one of the roots of the wing along the wing following the sweep, or the perpendicular distance from the x-z plane (true body axis of the aircraft), where the two halves of the flying wing join?	Store separation distance is normal to the flight axis of the aircraft..
For a high or low wing mounted on a tube-like fuselage, is the 3" referenced from the rocket's centerline to the root of a wing-half (x-z plane) or the the axis of the fuselage body tube?.	This is in the rules: The most inboard store(s) centerline must be at least 3" from the aircraft centerline. Centerline is not the rotation axis of the fuselage for a tubular fuselage.
What defines a "centerline" when there is no centrally positioned fuselage, e.g. asymmetric plane with no fuselage?	For a flying wing with no discernable body, bumps, thickness changes, or blisters the centerline will be the mid-

<p>What defines left and right wing in the case of no, or off-center, fuselage, e.g. flying wing, or tube and wing, with an asymmetric wing?</p>	<p>span plane. For unconventional configurations see the answer in the general section above.</p>
<p>Can we have an inboard most pylon on our plane such that for CG testing, when the Der Red Max is fit onto it, it will obstruct the bay door, but during flight, the Der Red Max will be placed on a different pylon?</p>	<p>This is in the rules: External stores may not overlap/block the access/deployment area of internal store location(s).</p>
<p>If the chosen configuration of our aircraft utilizes multiple wings, must all the rockets be carried on the lowest wing? How can external payload be "launched" (as in for clearance purposes, not actual firing)? Can we assume both rail and ejector release mechanisms can be used (i.e., ejector only requires vertical clearance whilst rail requires only horizontal clearance)? For example, in a biplane configuration the payload could be fired from between the wings using a rail system, but not an ejector system.</p>	<p>Wing mounted rockets must not have any aircraft structure located below them. They must be located such that they "could" free-fall or be loaded from directly underneath.</p>
<p>For the Mission 3 configurations requiring more than 2 external stores, can we choose which store is inboard and which is outboard? In other words, can we choose the positions of the external stores?</p>	<p>The mission matrix does not specify which store is inboard or outboard, or for single stores on a wing if you must use the inboard or outboard pylon.</p>
<p>The rules state "Store fins must be below the wing lower surface trailing edge height"</p> <p>Viewing the wing from above, can parts of the rocket protrude past the wingtip in the Y direction? For example, if the rocket center-line was directly under the wingtip, half of the rocket would be under the wing and the other half would be past the wingtip. Is this legal?</p>	<p>If the store lies below the plane of the wing trailing edge it is allowed. Be sure to note the SF responses in the General section above.</p>
<p>Would gluing the removable wing pylons to the external stores count as modifying their design if it is done only for the final mission?</p>	<p>Stores may not be glued to the pylons. See section above for more on attachments to the pylons.</p>
<p></p>	<p></p>